



# SAM TURBO INDUSTRY PRIVATE LIMITED

Excellence ▶ *Through* ▶ Innovation

| Home | About us | Infrastructure | Products | Clientele List | Client Certificate | Contact | Feedback | Sign out |



Excellence ▶ *Through* ▶ Innovation

*Pumping out Right Solution Consistently*

[www.sampumps.com](http://www.sampumps.com)

### ::: About Us :::

As a new set of rules emerge, the key to success lies in anticipating and understanding them. This has been a way of life at **SAM TURBO INDUSTRY PRIVATE LIMITED**, a multi-crore, dynamic engineering company.

A humble beginning from a dream and a sound technical and business focus, directed the efforts of **Mr K. Sambath Kumar**, the CMD of the company to focus his attention towards the Slurry Chemical of Pulp & Paper Industries. Then, a product which very few pump manufacturers were competent at, SAM programmed its success story around this category.

With over 40 years of experience and elaborate infrastructure at their disposal, the growing and liberal economy, and the young and dynamic leadership of their **Joint Managing Director, Mr S.K.SENTILKUMAR**, SAM pumps is now poised to take on new challenges in future.

SAM designs, manufactures, and services pumps for the essential industries in India and abroad. Since 1972, SAM has built a reputation of blending craftsmanship with **mass production, techniques with innovation, quality, and quantity**. Today SAM is an acknowledged leader in its industry and continues to combine innovative designs and materials with most advanced manufacturing techniques to ensure quality and quantity.

The company has its corporate office, captive steel foundry and manufacturing plants at **Coimbatore, Tamil Nadu - South India**.

The company's product range includes both **horizontal and vertical centrifugal pumps**, with closed and open impellers. These pumps today form an integral part of **Thermal Power Stations, Paper, Chemical, Basic Metals, Fertilizers Industries, Refineries and Petrochemical** etc. Apart from this, SAM Pumps have crossed the seas to find a presence in a host of industrial applications abroad.

SAM has a captive steel foundry with a capacity of 400 M.T./Month producing materials confirming to IS, ASTM, JIS, AFNOR and BS standards, guaranteeing excellent quality control standards for its products.



## ::: Infrastructure :::



## CAPTIVE STEEL FOUNDRY







## ::: Captive Steel Foundry :::

### Materials from Sam's Captive Steel Foundry confirming to IS, ASTM, JIS, AFNOR & BS

Graded Cast Iron / CA-15 / CA-40 / LCB / WCB / CF8(SS-304) / CF3(SS-304L) / CF8M(SS-316) / CF3M(SS-316L) / CG8M(SS-317) / CG3M(SS-317L) / SS-2324 (DIN -1.4460) / CD4MCu / CN7M (Alloy-20) / Hast Alloy-BC.. / Hi Chrome (600BHN) / Ni Hard / AFNOR-Z-180-C13(550BHN) / E-230-480M / Sanicro-28 / Ni Resist / CA6NM / R-55 / UB-55 / Worthite / Noridur / UB6 / Alloy-2205 / 904L





## ::: Products :::

AR/ARS - SLURRY PUMPS

TPS PULP & PAPER STOCK PUMPS

TPS+H MEDIUM CONSISTENCY PUMPS

SPS PULP & PAPER STOCK PUMPS

CPC CHEMICAL PUMPS

TCH+N ANSI-PROCESS PUMPS

ZM/AD HORIZONTAL SPLIT CASE PUMPS

MF MIXED FLOW PUMPS

WP WATER PUMPS

VO VERTICAL PUMPS

MD MULTI-STAGE PUMPS

SVN API PROCESS PUMPS



## ::: Products - AR / ARS SLURRY PUMPS :::

CROSS SECTION CAD DRAWING



### Operating Range

Delivery Size	: DN 50 to 400 mm
Capacity	: Up to 2000m <sup>3</sup> /hr
Head	: Up to 60m/stage
Temperature	: Up to 110°C
Pressure	: Up to 25 bar

### Features

- » Twin casing / Single casing design
- » Heavy duty & single stage
- » Outer casing in CI / Carbon steel
- » Inner casing in Ni-hard / Hi-chrome to take entire wear

### Application

- » Ash slurry in thermal power stations
- » Aluminium Industries - Hydrate, Seed, Bauxite and Red mud Slurries
- » Lime mud slurry, Milk of lime, Liquor upto 50% solids
- » Coal slurries & floatation tailings
- » Iron ore in beneficiation plants
- » Sand water mixtures
- » Liquids of abrasive and coarse grained solids

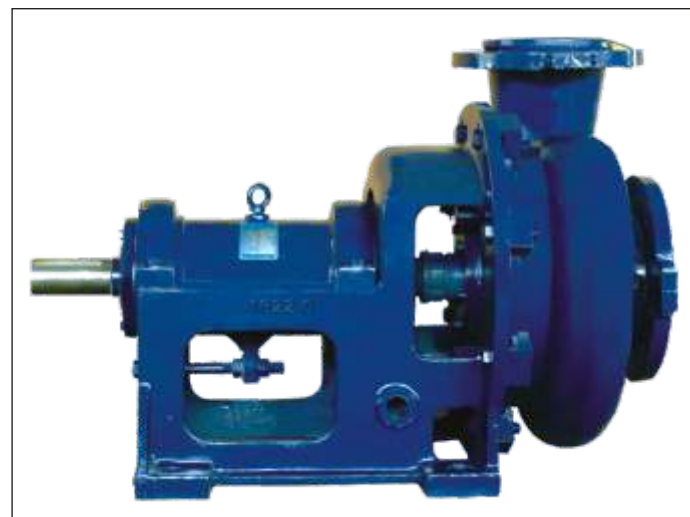





## ::: Products - AR / ARS SLURRY PUMPS :::

BACK AR/ARS SLURRY PUMPS

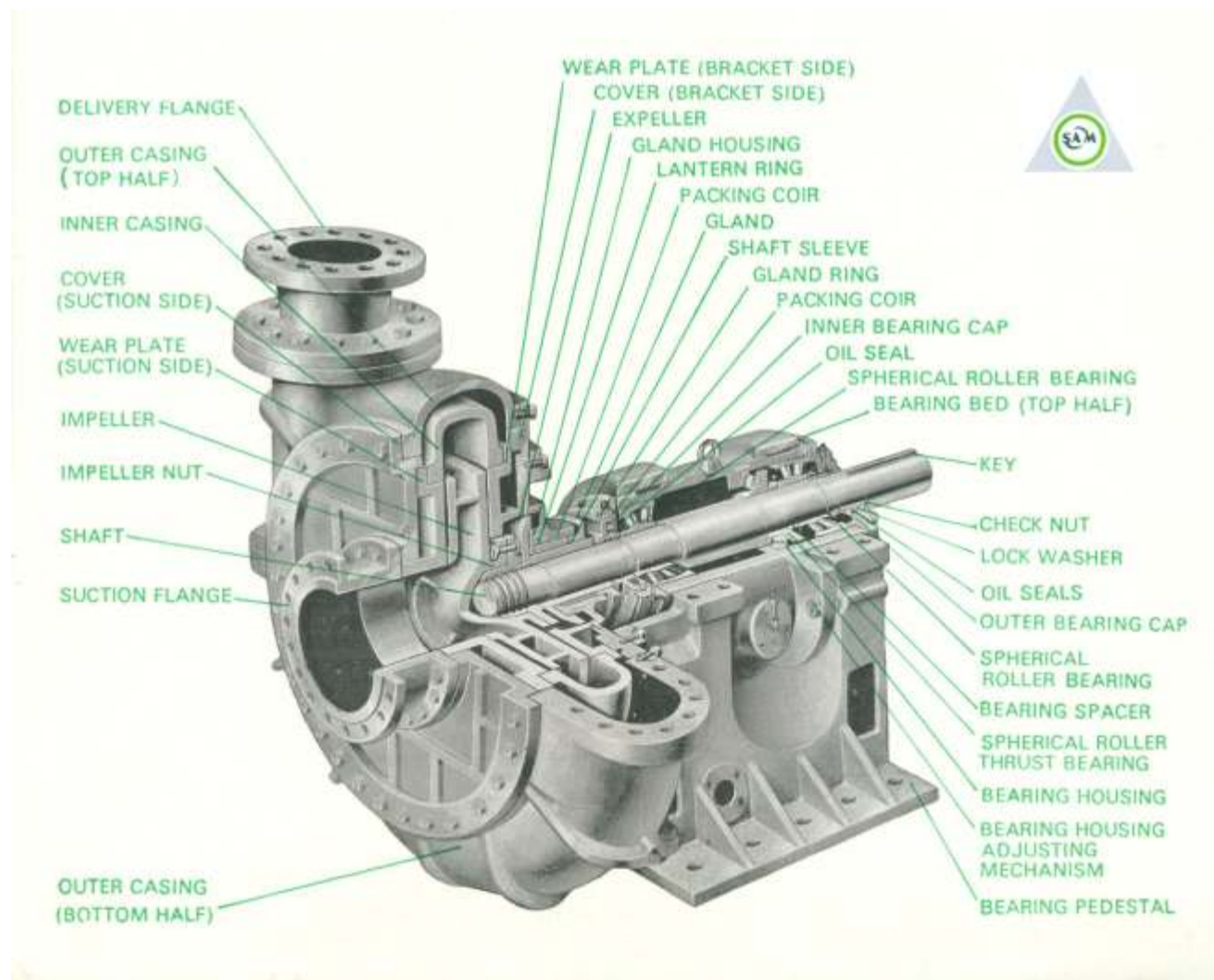

## ::: Products - TPS PULP & PAPER STOCK PUMPS :::

CROSS SECTION CAD DRAWING



### Operating Range

Delivery Size	:	DN 32 to 350 mm
Capacity	:	Up to 2250m <sup>3</sup> /hr
Head	:	Up to 80m
Temperature	:	Up to 140°C
Pressure	:	Up to 22 bar

### Features

- » Heavy Duty Centrifugal Design
- » Conforming to DIN 24256
- » Open impellers with renewable front wear plate and closed impeller with wear-ring
- » Simple external adjustment for impeller wear
- » Gland packed / mechanical seal

### Application

- » Handling pulp & paper stocks upto 7% consistency
- » All liquor applications in basic metal & pulp & paper industries
- » Suitable for high capacity requirement of acids, alkaline, corrosive slurries etc.,
- » Suitable for heavily contaminated liquids, raw sewage, Sludge







## ::: Products - TPS PULP & PAPER STOCK PUMPS :::

BACK TPS PULP & PAPER PUMPS

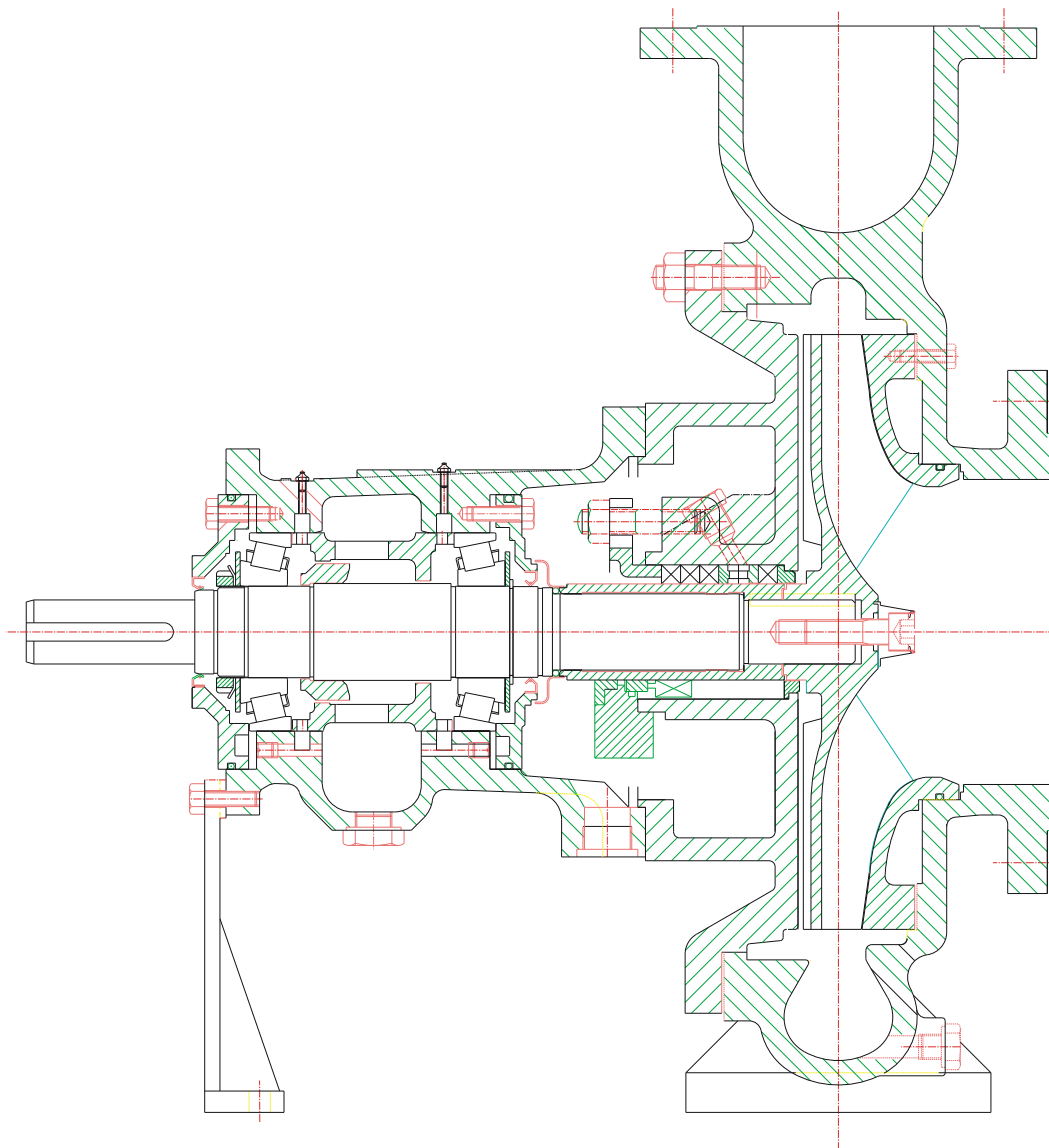

## ::: Products - TPS +H MEDIUM CONSISTENCY PUMPS :::

CROSS SECTION CAD DRAWING



### Operating Range

Delivery Size	:	DN 80 to 200 mm
Capacity	:	Up to 250m <sup>3</sup> /hr
Head	:	Up to 110m
Temperature	:	Up to 150°C
Pressure	:	Up to 22 bar

### Features

- » Centrifugal & Single Stage
- » Open impeller with fluidizer
- » End suction & Top discharge
- » Sturdy & vibration free mounting to the base

### Application

- » Reliable pumping of pulp stock from 8% to 18% consistency
- » Supplied along with vacuum pump - in-buit / external mounted





## ::: Products - TPS +H MEDIUM CONSISTENCY PUMPS :::

BACK TPS +H PUMPS

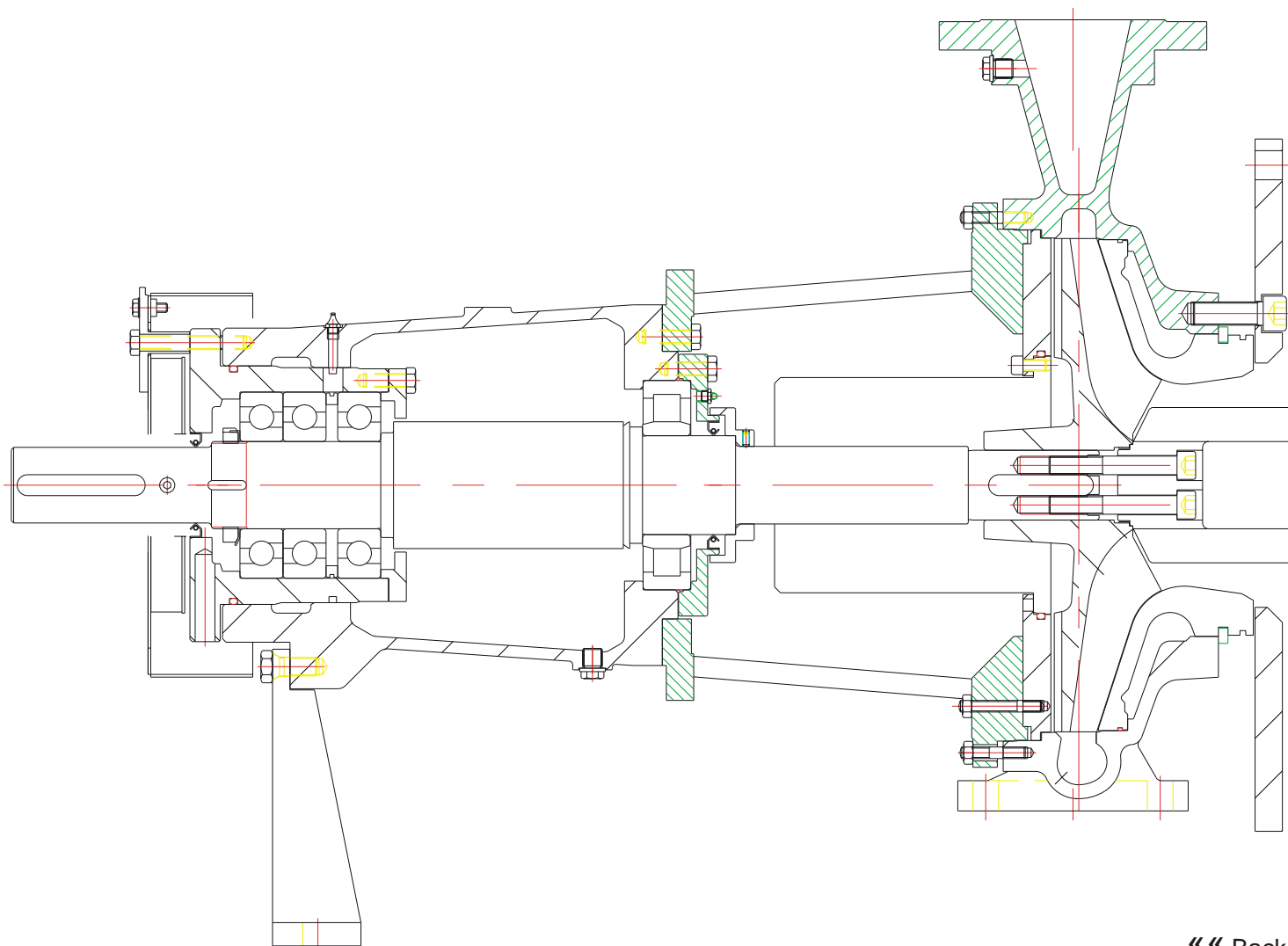

## ::: Products - SPS PULP & PAPER STOCK PUMPS :::

CROSS SECTION CAD DRAWING



### Operating Range

Delivery Size	:	DN 32 to 300 mm
Capacity	:	Up to 1800m <sup>3</sup> /hr
Head	:	Up to 150m
Temperature	:	Up to 140°C
Pressure	:	Up to 22 bar

### Features

- » DIN 24256 Std
- » Open impellers with renewable front wear plate and closed impeller with wear - ring
- » Simple external adjustment for impeller wear from suction side
- » Gland packed / mechanical seal

### Application

- » Handling pulp & paper stocks upto 8% consistency
- » All liquor applications in basic metal & pulp & paper industries
- » Suitable for high capacity requirement of acids, alkaline, corrosive slurries etc.,
- » Suitable for heavily contaminated liquids, raw sewage, Sludge







## ::: Products - SPS PULP & PAPER STOCK PUMPS :::

BACK SPS PUMPS

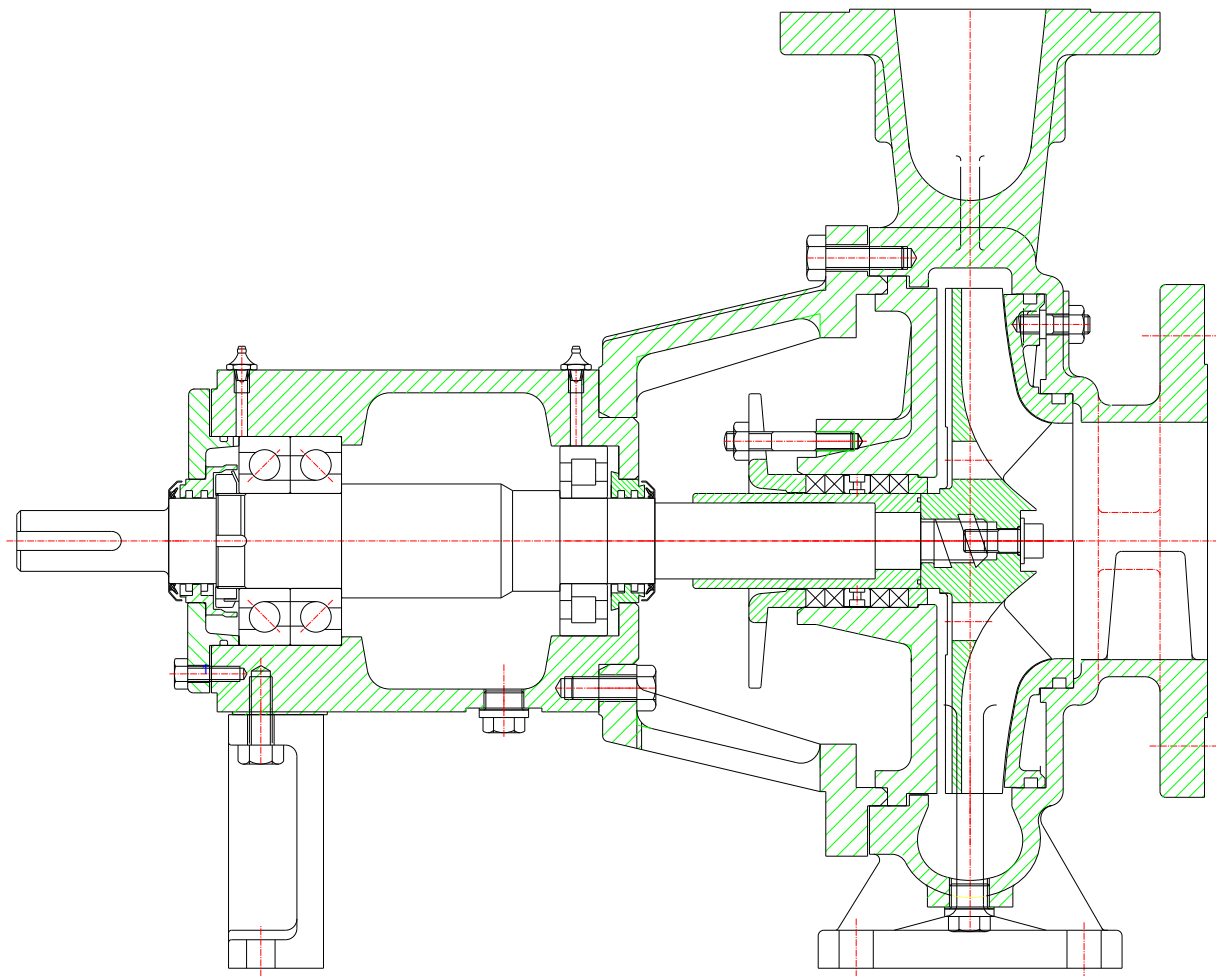

## ::: Products - CPC CHEMICAL PUMPS :::

CROSS SECTION CAD DRAWING



### Operating Range

Delivery Size	:	DN 32 to 200 mm
Capacity	:	Up to 750m <sup>3</sup> /hr
Head	:	Up to 150m
Temperature	:	Up to 200°C
Pressure	:	Up to 22 bar

### Features

- » Conforming to DIN 24256 / ISO 2858
- » Back pull out design
- » Engineered to API - 610 - 6th edition
- » Only four bearing beds to cover 32 models
- » Closed impeller
- » Gland packed / mechanical seal

### Application

- » Process, Petrochemicals, Refineries, Fertilizers, Paper & Sugar
- » Handling corrosive acids, alkalies
- » Hydrocarbons, Oils, Thermic fluids
- » Clarified water, back water, white water, De-inking water, soft water, centric cleaner application in pulp & paper mills





## ::: Products - CPC CHEMICAL PUMPS :::

BACK CPC PUMPS

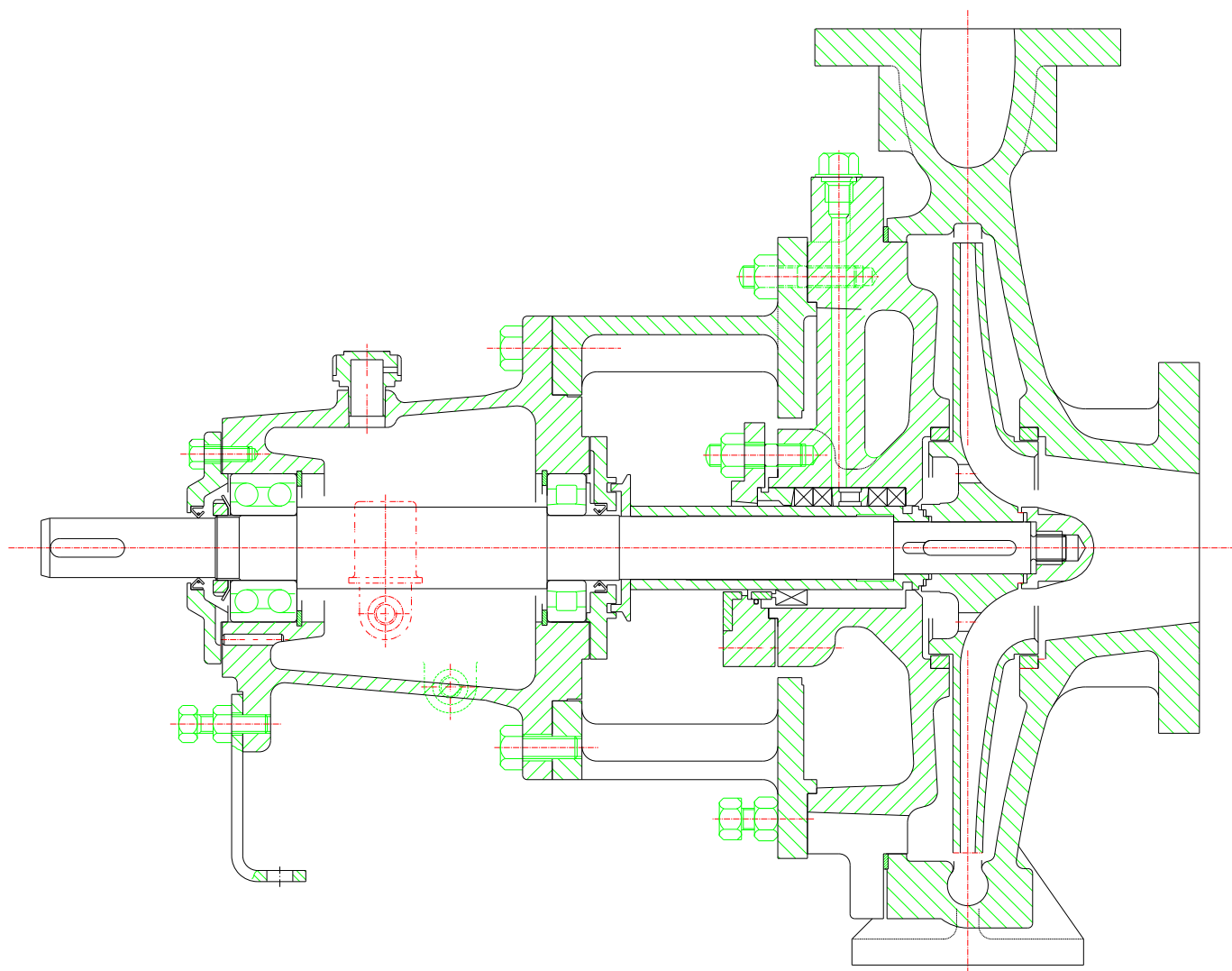

## ::: Products - TCH + N ANSI - PROCESS PUMPS :::

CROSS SECTION CAD DRAWING



### Operating Range

Delivery Size	:	DN 25 to 200 mm
Capacity	:	Up to 700m <sup>3</sup> /hr
Head	:	Up to 180m
Temperature	:	Up to 200°C
Pressure	:	Up to 26 bar

### Features

- » Conforming to ANSI B73.1
- » Open impeller construction
- » End suction / Top centre line discharge
- » Only 3 bearing beds to cover 32 models
- » Gland packed / mechanical seal
- » Simple external adjustment for impeller wear

### Application

- » Handles all chemical process requirements
- » Acids, alkalis corrosive slurries
- » Suitable for all liquids with / without solids
- » Green liquor, black liquor, Caustic Slurry, lime-mud slurry, extraction, Alkalies, Acids, NaOH, China clay, Filtrate, Hypo, Spent wash, starch etc in pulp & paper mills & basic metal industries







## ::: Products - TCH + N ANSI - PROCESS PUMPS :::

BACK TCH + N PUMPS

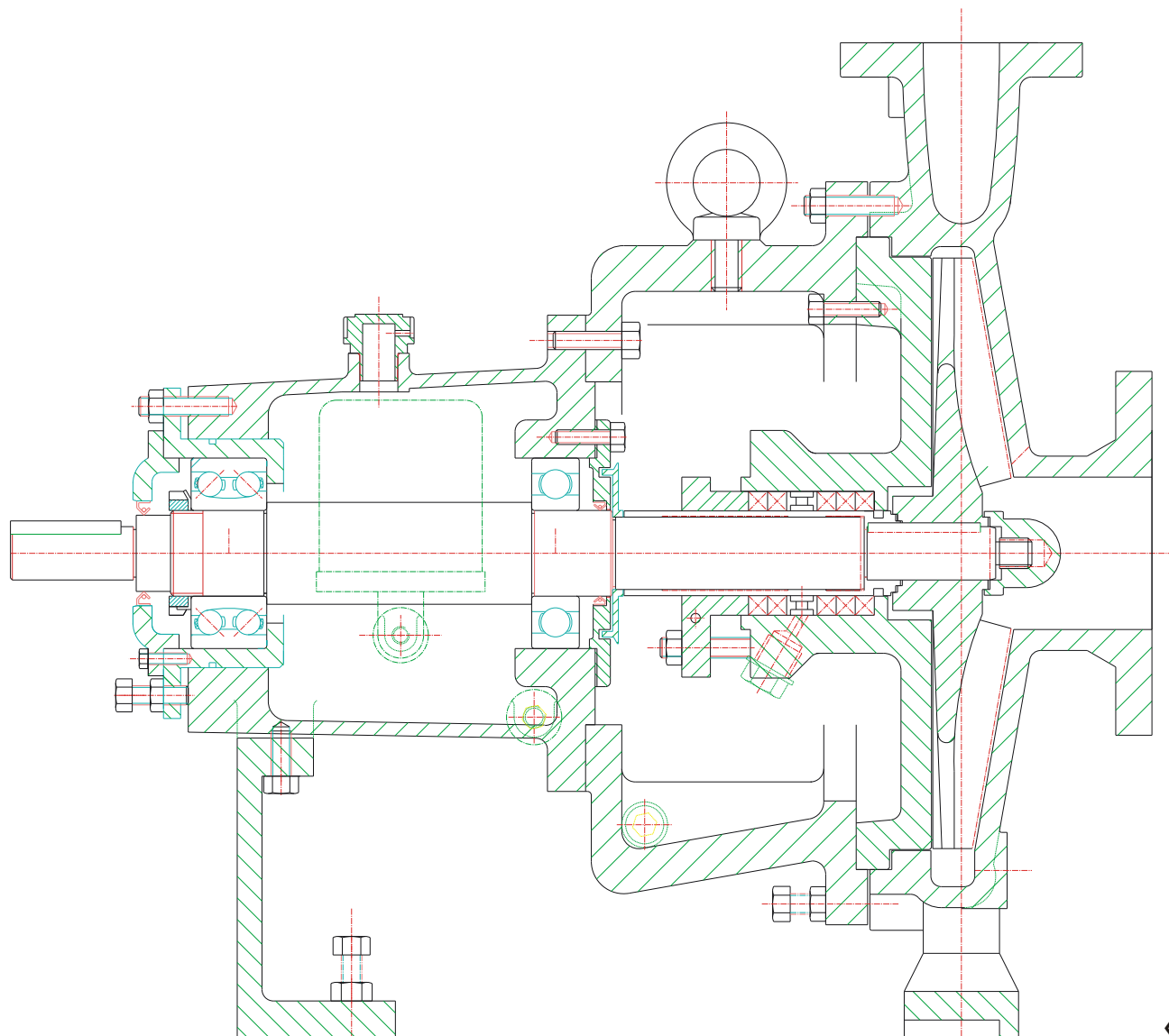

## ::: Products - ZM /AD HORIZONTAL SPLIT CASE PUMPS :::

CROSS SECTION CAD DRAWING



### Operating Range

Delivery Size	: DN 50 to 700 mm
Capacity	: Up to 4000m <sup>3</sup> /hr
Head	: Up to 140m
Temperature	: Up to 220°C
Pressure	: Up to 40 bar

### Features

- » Axil split, single / two stage
- » Double suction, radial impeller
- » High reliability & vibration free performance
- » Gland packing / mechanical seal
- » Reverse rotation available

### Application

- » Water, fire-fighting
- » Fan pump, stock feed, stock circulation, centri - cleaner application in pulp & paper mills
- » Storm water, irrigation
- » Industries transfer works





## ::: Products - ZM /AD HORIZONTAL SPLIT CASE PUMPS :::

BACK ZM/AD PUMPS

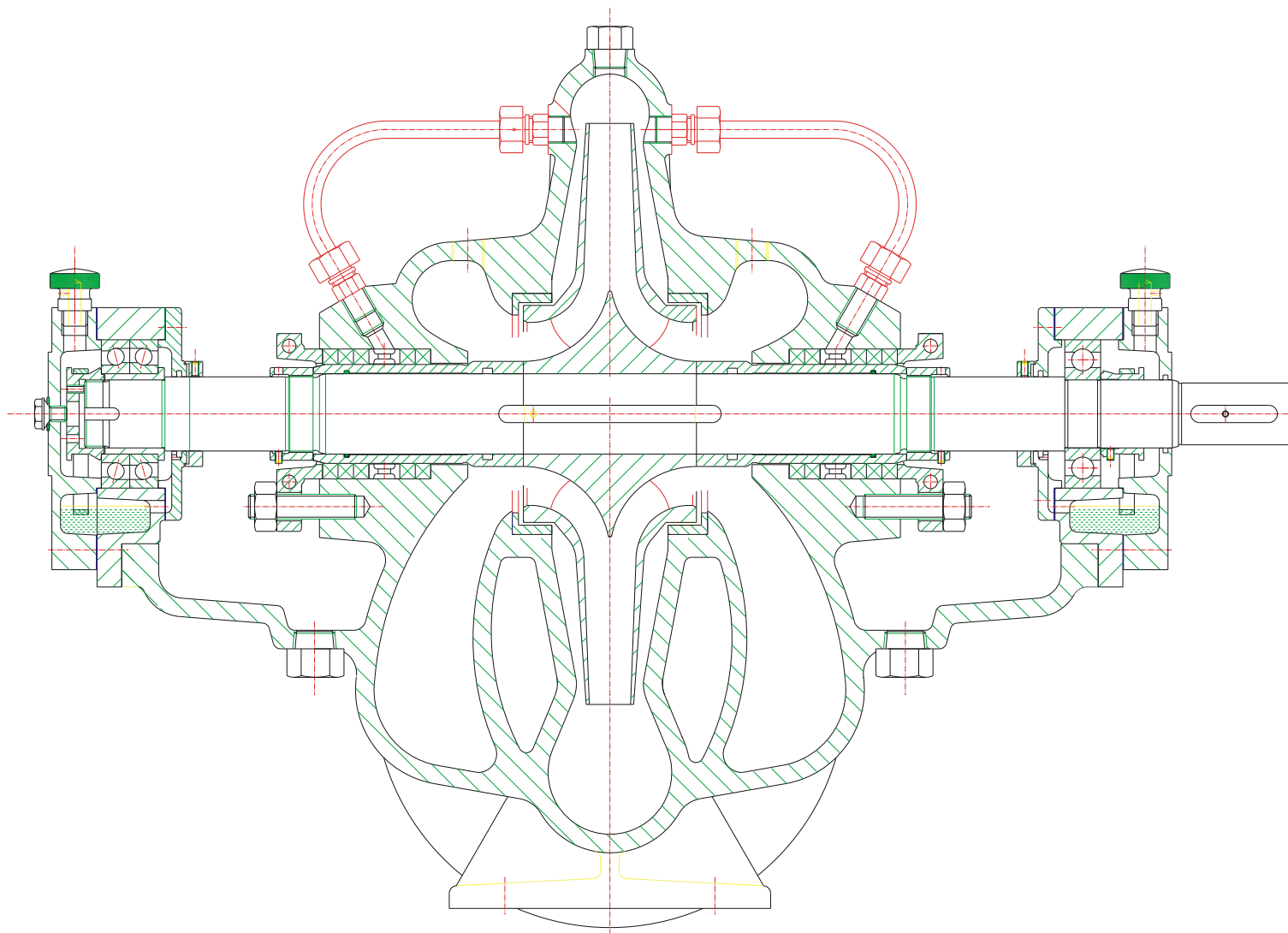

## ::: Products - MF MIXED FLOW PUMPS :::

CROSS SECTION CAD DRAWING



### Operating Range

Delivery Size	:	DN 200 to 450 mm
Capacity	:	Up to 3000m <sup>3</sup> /hr
Head	:	Up to 40m
Temperature	:	Up to 110°C
Pressure	:	Up to 7.5 bar

### Features

- » Horizontal, Single stage
- » End suction & discharge branch arranged tangentially upwards / Horizontal
- » Open impeller construction

### Application

- » Clean, turbid or slightly contaminated liquids
- » Medium & Low heads in water works  
Sewage works
- » Irrigation & drainage
- » De-watering & pumping sea water
- » Spray pond / injection water applications in sugar mills
- » Pulp transfer / centri cleaner in pulp & paper mills







## ::: Products - MF MIXED FLOW PUMPS :::

BACK MF MIXED FLOW PUMPS

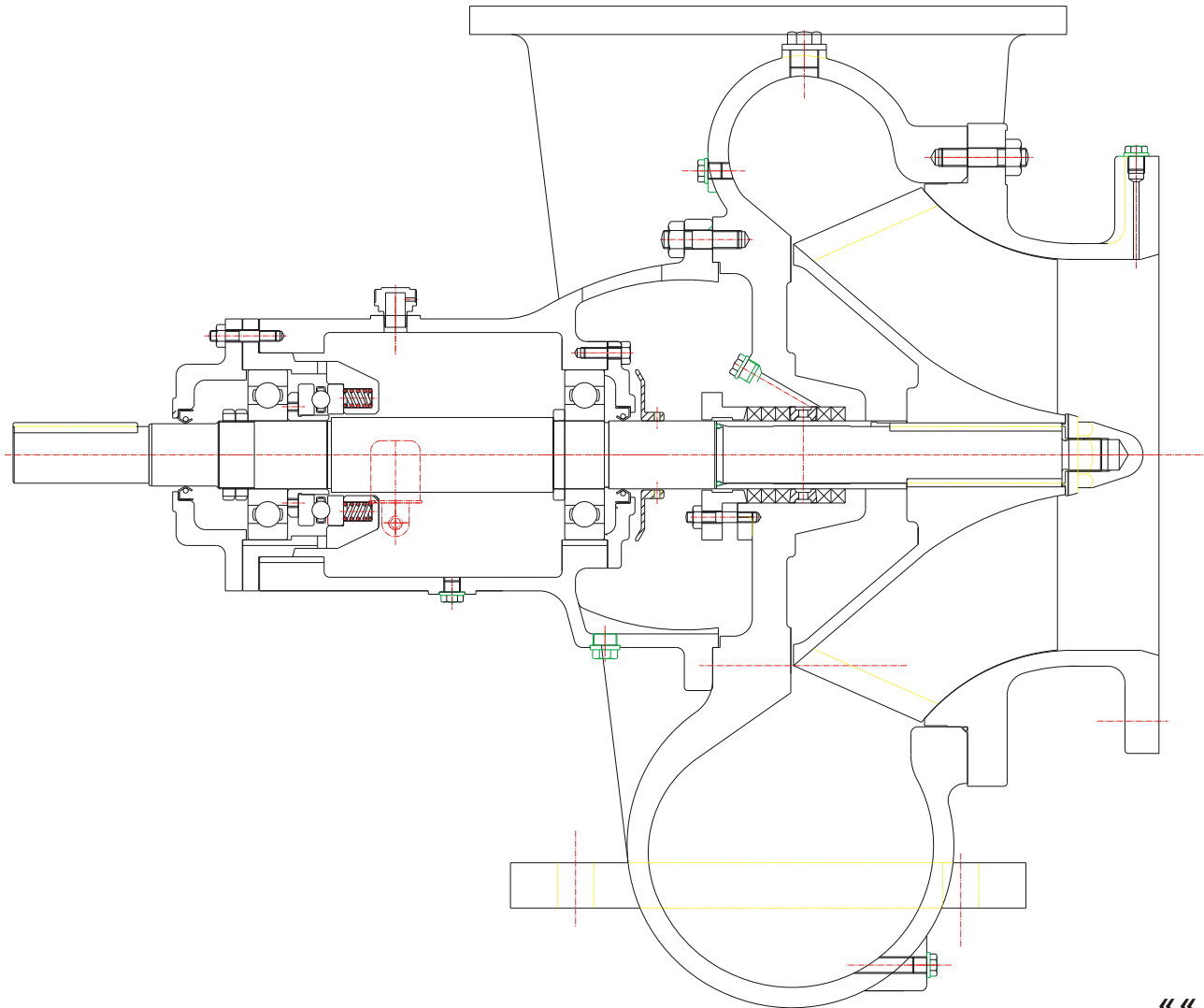

## ::: Products - WP WATER PUMPS :::

CROSS SECTION CAD DRAWING



### Operating Range

Delivery Size	:	DN 32 to 150 mm
Capacity	:	Up to 550m <sup>3</sup> /hr
Head	:	Up to 100m
Temperature	:	Up to 120°C
Pressure	:	Up to 16 bar

### Features

- » Conforming to DIN 24255
- » Back pull out design
- » Gland packed / Mechanical seal
- » Closed impeller construction
- » Only 3 bearing beds to cover 30 models

### Application

- » General water Supply in agriculture & Industries
- » Fire - fighting
- » Booster service
- » Clarified water, back water, white water, De-inking water, soft water, centri cleaner etc., in pulp & paper mills





## ::: Products - WP WATER PUMPS :::

BACK WP WATER PUMPS

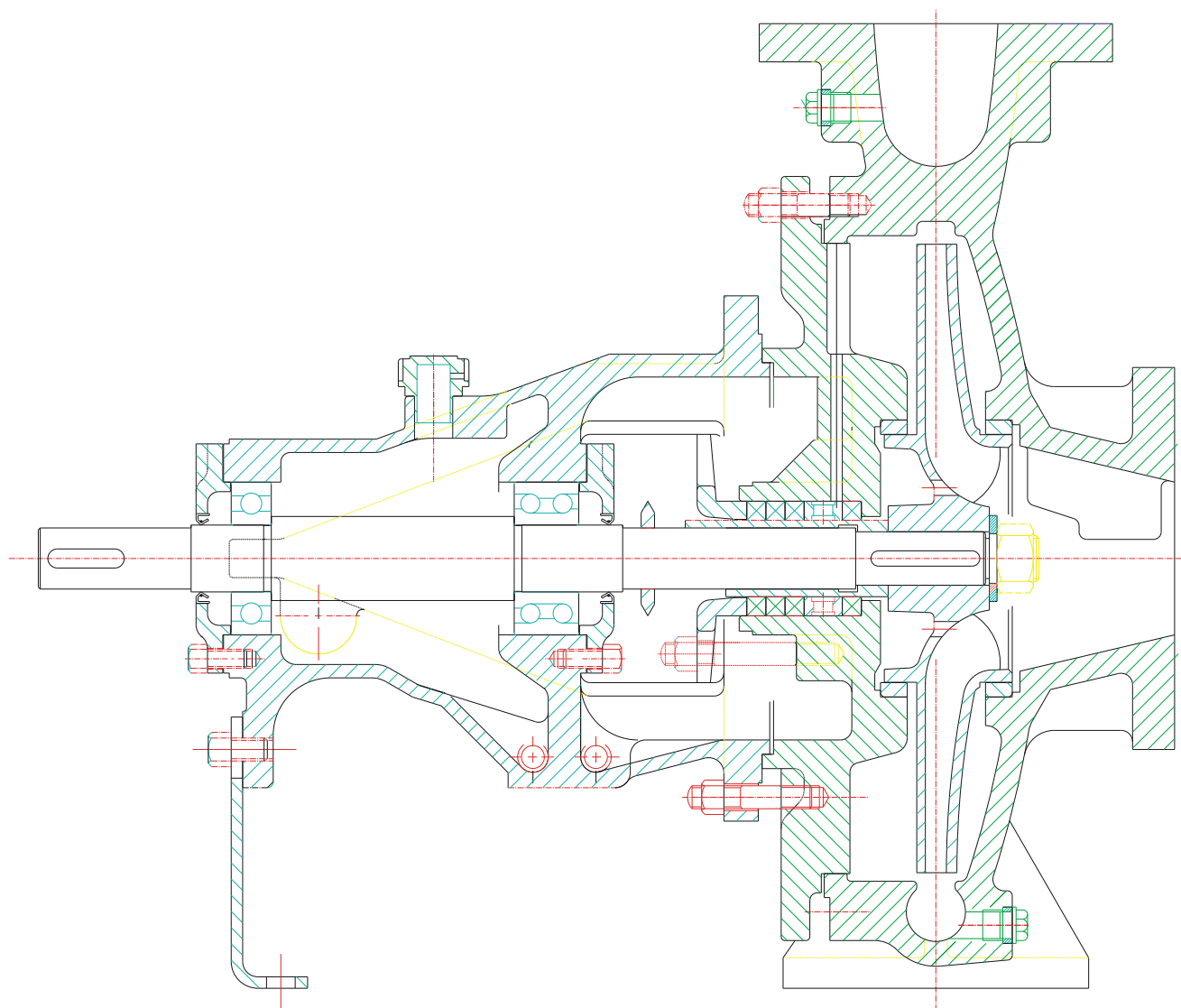

## ::: Products - VO VERTICAL PUMPS :::

CROSS SECTION CAD DRAWING



### Operating Range

Delivery Size	:	DN 25 to 300 mm
Capacity	:	Up to 900m <sup>3</sup> /hr
Head	:	Up to 120m
Temperature	:	Up to 120°C
Pressure	:	Up to 22 bar

### Features

- » Vertical suspended with open / closed impellers
- » Cantilever design & with intermediate bush bearing support
- » Simple mount & self priming
- » Up to 10 mtrs submersion depth
- » Simple, fast external impeller adjustment

### Application

- » Suitable where space economy matters
- » Suitable for Acids, Alkalies & Slurries in basic metal industries
- » Waste water, Sludge handling in pulp & paper industries





## ::: Products - VO VERTICAL PUMPS :::

BACK VO VERTICAL PUMPS

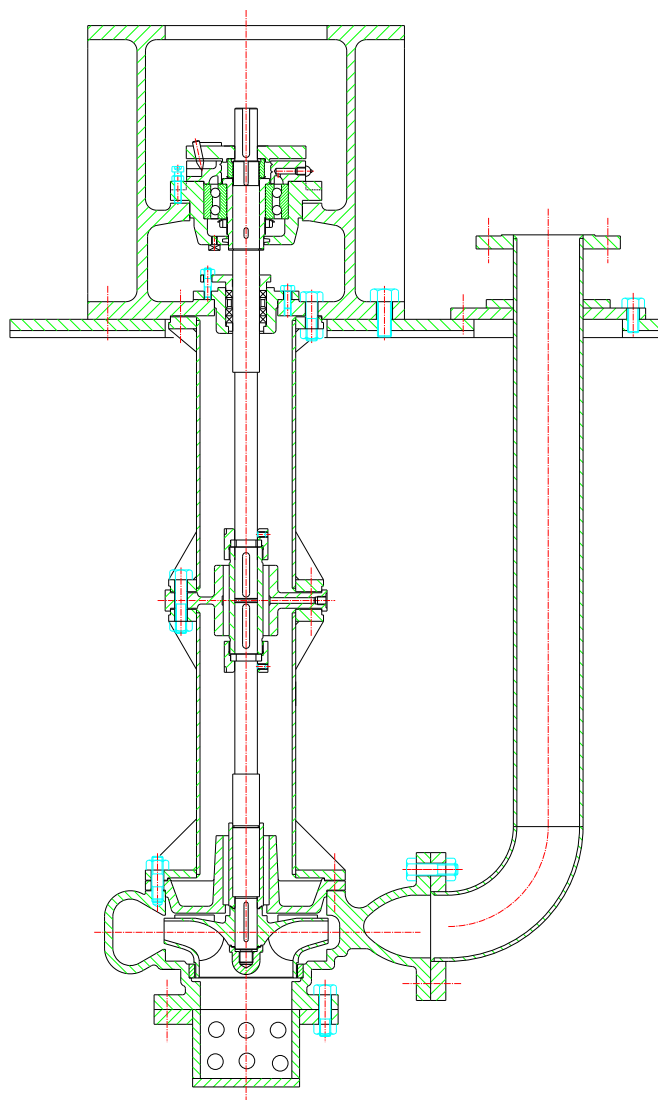



## ::: Products - MD MULTI-STAGE PUMPS :::

CROSS SECTION CAD DRAWING



### Operating Range

Delivery Size	:	DN 40 to 125 mm
Capacity	:	Up to 350m <sup>3</sup> /hr
Head	:	Up to 600m
Temperature	:	Up to 180°C
Pressure	:	Up to 90 bar

### Features

- » Barrel type construction
- » Multi stage with suction - closed impeller
- » Axial thrust compensated by balancing disc

### Application

- » Boiler feed water service
- » Main & auxiliary condensate extraction
- » General water & fire - fighting systems
- » Mine - de-watering & descaling
- » High pressure application in pulp & paper mills





## ::: Products - MD MULTI-STAGE PUMPS :::

BACK MD MULTI-STAGE PUMPS

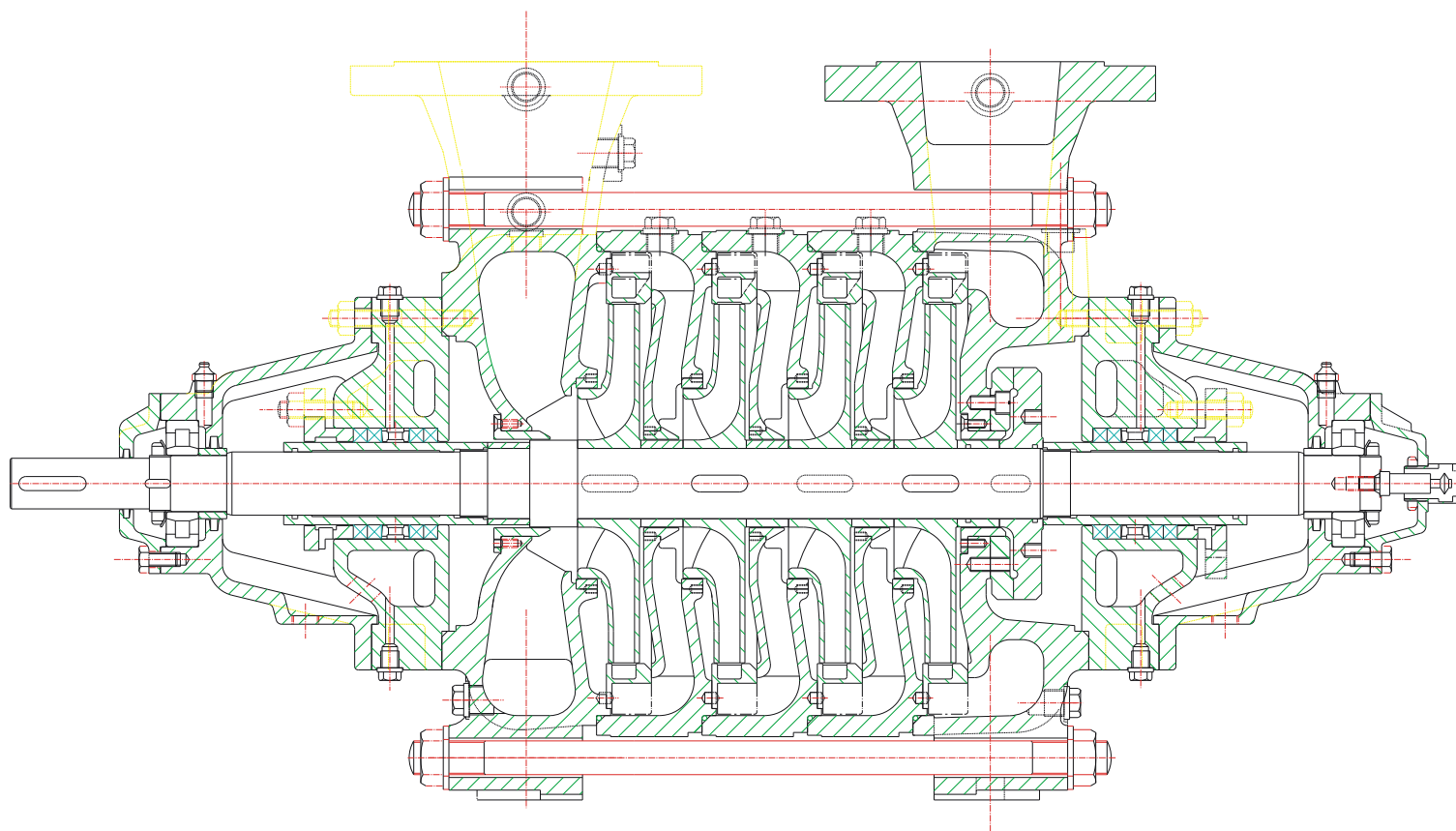

## ::: Products - SVN API PROCESS PUMPS :::

CROSS SECTION CAD DRAWING



### Operating Range

Delivery Size	:	DN 25 to 250 mm
Capacity	:	Up to 1000m <sup>3</sup> /hr
Head	:	Up to 300m
Temperature	:	Up to 450°C
Pressure	:	Up to 60 bar

### Features

- » Conforming to API 610 7th edition
- » Centre-line mounting
- » Heavy duty shaft & bearings
- » Double volute to minimize radial thrust (above 3" discharge)
- » Renewable impeller and casing wear-rings.

### Application

- » Process industries & transfer system
- » Refineries, Oil & Gas fields, on/off-shore
- » Petro Chemicals
- » Heat carrier system
- » Boiler cleaning





## ::: Products - SVN API PROCESS PUMPS :::

BACK SVN API PUMPS

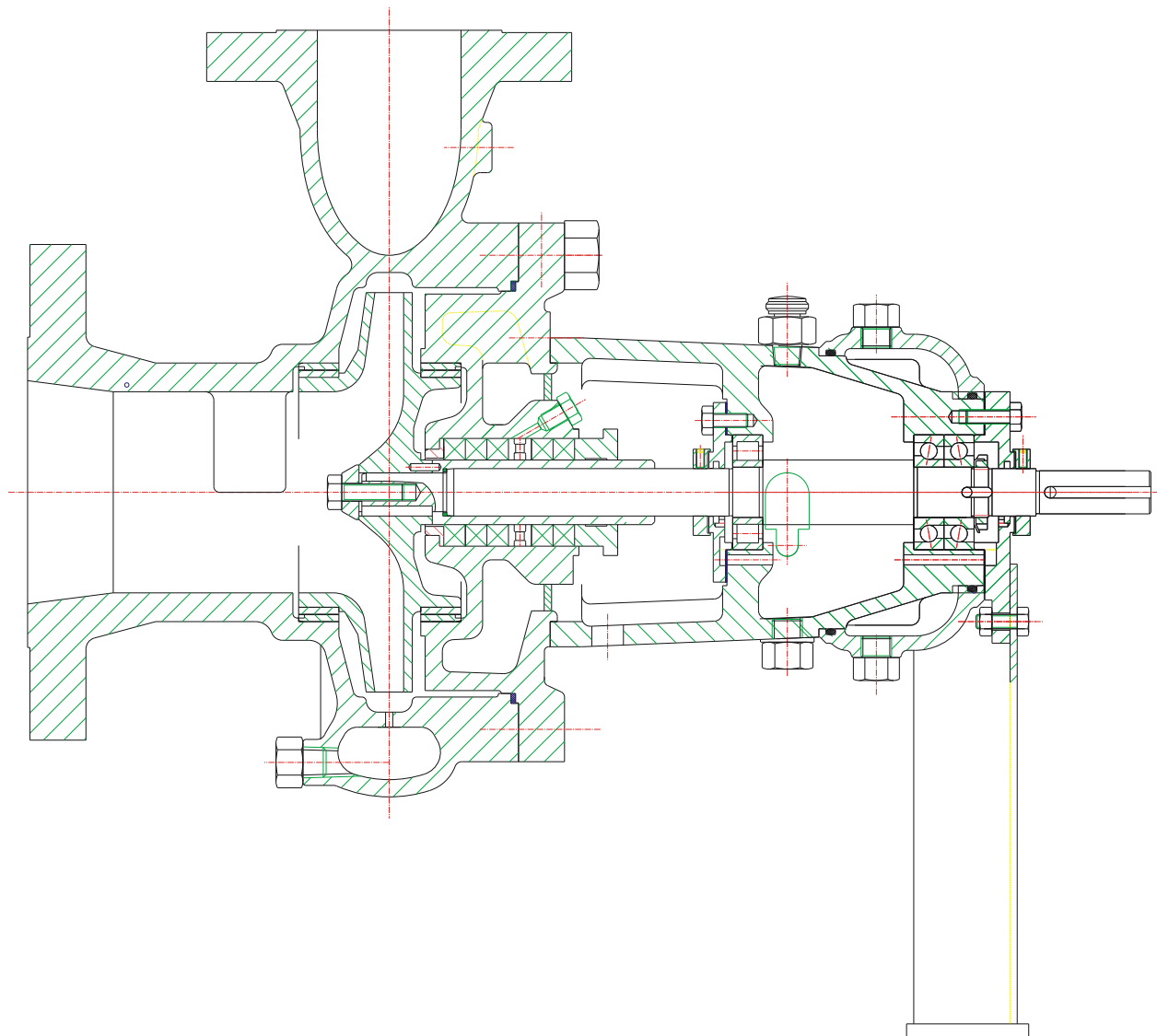



# SAM TURBO INDUSTRY PRIVATE LIMITED

Excellence ▶ *Through* ▶ Innovation

| Home | About us | Infrastructure | Products | Clientele List | Client Certificate | Contact | Feedback | Sign out |

## ::: CLIENTELE LIST :::

### Thermal Power Station

01. Andhra Pradesh Power Generation Co Ltd.
02. Bhilai Electricity Supply Co Ltd,
03. Bokaro Power Supply Corporation Ltd.
04. Chattishgarh State Electricity Board
05. Damodar Valley Corporation
06. Gujarat State Electricity Corporation Ltd.
07. Haryana State Electricity Board
08. Karnataka Power corporation Ltd
09. Madhya Pradesh Power Generating Co. Ltd.
10. Maharastra State Power Generating Co. Ltd.
11. Nalco Captive Power Plant
12. National Thermal Power Corporation Ltd.
13. Neyveli Lignite Corporation Ltd
14. NSPL, Rurkela
15. Tamilnadu Electricity Board
16. Uttar Pradesh State Electricity Board
17. West Bengal Power Corporation Ltd.
18. Rajasthan Rajya Vidhyut Utpadan Nigam Ltd.
19. U.P. Rajya Vidhyut Utpadan Nigam Ltd.
20. Nuclear Power Corporation of India Ltd

### Chemical Industries

01. Aditya Birla Nuvo Ltd.
02. Chandigarh Distillers & Bottlers Ltd.
03. Kilburn Chemical Ltd.
04. Grasim Industries Ltd.
05. Biral Cellulosic
06. Bayer ABS Industries
07. Reliance Industries Ltd
08. Transpek Industries Ltd
09. Gujarat Fluoro Chemicals
10. Gujarat Heavy Chemicals Ltd
11. Nirma Limited
12. ONGSC
13. Saurashtra Chemical Ltd
14. Sterling Geletin

### Chemical Industries

- |                                      |   |                    |
|--------------------------------------|---|--------------------|
| 1. PT Indobharat Rayon               | - | Jagarth, Indonesia |
| 2. Thai Rayon                        | - | Bangkok            |
| 3. Alexandria Carbon Black           | - | Egypt              |
| 4. ALMOZAYEK for Paper and Cardboard | - | Damascus, Syriya   |
| 5. Muffindi Paper Mills Ltd          | - | Mgolo, Tanzania    |
| 6. Crown Paper Mills                 | - | Dubai              |
| 7. Union Paper Mills                 | - | Dubai              |
| 8. Swazi Paper Mills                 | - | Swaziland          |
| 9. Gayatrisakthi                     | - | Swaziland          |
| 10. Chemaf S.P.R.L.                  | - | Congo              |
| 11. Middle East Paper                | - | Saudi Arabia       |

### Fertilizer Industries

01. Coromandal Fertilizers Ltd
02. EID Parry (India) Ltd
03. Fertilizer & Chemical Travancore Ltd.
04. Gujarat State Fertilizers Ltd
05. Indian farmer Fertilizer Co-operation Ltd
06. Madras Fertilizer Ltd.
07. Mangalore Chemicals & Fertilizers Ltd
08. Paradeep Phosphates Ltd
09. Southern Petro Chemical Industries Corp. Ltd
10. Tuticorin Alkali & Chemical Ltd

### Metal Industries

01. Binani Zinic Ltd
02. Birla Copper (Hindalco Industries Ltd)
03. Essar Steel
04. Hindalco Industries
05. Vedanta Aluminium Ltd
06. Jhagadia Copper Ltd (SWILL Ltd)
07. Jindal Steel Ltd
08. National Aluminium co Ltd
09. Steel Authority of India Ltd
10. Sterlite Industries Ltd
11. Hindustan Zinc Ltd

### Consultants

01. Aker Powergas India Ltd
02. Uhde India Limited
03. Development Consultants (P) Ltd
04. Fact Engg & Design Organisation
05. Mecon Ltd
06. SPB Project & Consultancy Ltd
07. SNC-Lavalin Engg. India (P) Ltd
08. TCE Consulting Engineers Ltd
09. Jacobs Engg. India Pvt., Ltd
10. Desin (P) Ltd
11. Tata Consulting Engineers
12. Tata Projects Ltd

### Major Client Pulp & Paper

- ABHISHEK INDUSTRIES LTD  
 ANDRA PRADESH PAPER MILLS LTD  
 BALLARPUR INDUSTRIES LTD-ALL UNITS  
 BINDLAS DUPLEX LTD  
 CHADHA PAPER LTD  
 DELTA PAPER MILLS  
 DHANALAKSHMI PAPER MILLS LTD  
 EMAMI PAPER MILLS LTD  
 ECO PAPER  
 GENUS PAPER MILLS LTD  
 GLOBAL BOARDS LTD  
 GREENLAND PAPER MILLS LTD  
 HINDUSTAN PAPER CORP. LTD  
 ITC LIMITED  
 JK PAPERS LTD  
 KARUR KCP PACKAGING  
 KHANNA PAPER MILLS LTD  
 MAGNUM PAPER LTD  
 MALAR PAPER MILLS LTD  
 MURLI AGRO PRODUCTS  
 MYSORE PAPER MILLS LTD  
 NR AGARWAL INDUSTRIES LTD  
 ORIENT PAPER MILLS LTD  
 PUDUMJEE PULP & PAPER  
 RAINBOW PAPER LTF  
 RAMA NEWSPRINT & PAPERS LTD  
 RAMAN BOARDS LTD  
 RUCHIRA PAPER INDUSTRIES LTD  
 SAINSONS PAPER INDUSTRIES LTD  
 SERVALAKSHMI PAPER & BOARD (p) LTD  
 SHESHASAYEE PAPER & BOARDS LTD  
 SHREE SHYAM PULP & BOARD MILLS LTD  
 SIDHARTH PAPER MILLS LTD  
 SOUTH INDIA PAPER MILLS LTD  
 SREE SAKTHI PAPER MILLS LTD  
 SRIPATHI PAPER & BOARDS LTD  
 STAR PAPER MILLS LTD  
 SUBAM PAPERS  
 SUBBURAJ PAPER INDUSTRIES  
 SUN PAPER MILL LTD  
 TAMILNADU NEWS PRINT & PAPERS LTD  
 V.G. PAPER & BOARDS  
 VAMSHADHARA PAPER MILLS LTD  
 VIJAYALAKSHMI PAPER MILLS (p) LTD  
 WEST COAST PAPER MILLS LTD  
 YASH PAPER LTD  
 ZION PAPER MILLS LTD





# SAM TURBO INDUSTRY PRIVATE LIMITED

Excellence ▶ Through ▶ Innovation

| Home | About us | Infrastructure | Products | Clientele List | Client Certificate | Contact | Feedback | Sign out |

## ::: CLIENT CERTIFICATE :::

 **AVANT-GARDE ENGINEERS AND CONSULTANTS (P) LTD.**  
No. 68A, POBJUR KUNDRATHUR HIGH ROAD, POBJUR, CHENNAI - 600 116, INDIA  
TEL : 91-44-24827843, 24828532, 24828717, 18, 19, 20 FAX : 91-44-24828531  
E-mail : avantgarde@vni.com Web Site : http://www.avantgarde-india.com

16<sup>th</sup> February, 2013

M/s Sam Turbo Industry Pvt. Ltd.,  
Avimadu Road, Neelambur,  
Cumbassery-641042  
Ph: 0422-3018892

Kind Attn - Ms. Maria Francis  
CRM-Marketing

Dear Sir,

Sub: Registering with AVANT-GARDE as approved vendor.  
Ref: Your Application for Enrollment for Vendors.

We are pleased to inform you that your application for enrollment of vendor had been processed and found acceptable. We declare that you are one of our Approved Vendors and you can see your name listed in our list of Vendors at our web site for the following Product & Classification as:

The approval is now for:

1. M1-104.01 Centrifugal Pumps with MCW Pumps

With the above approval your company will be included in the master list of approved vendors.

For all our projects, the above master list will be sent to our clients, who in turn will select a few names from the list as their probable vendors. Registration with us does not mean confirmed issue of tender documents in projects. The approval of "List of vendors" is project specific.

Please note that this Approval of registration is valid till 16<sup>th</sup> February, 2013. This Approval can further be renewed on or before 16<sup>th</sup> February, 2013.

Yours truly,  
For AVANT-GARDE ENGINEERS & CONSULTANTS (P) LTD.

  
K. RAMANI  
Head - Vendor Registration Cell



Note: Please ensure the presence of our Histogram Sticker.

Business Power Plants, Mini Hydro Electric Plants, Renewable Energy  
Visit [www.avantgarde-india.com](http://www.avantgarde-india.com)  
[www.avant-garde.in](http://www.avant-garde.in)  
Sector:Manufacturers/Suppliers/Providers





 **Balkrishna Paper Mills Ltd.**

Corporate Office : 102, S. J. House, 1st Floor, Sistram Mill Compound, N. M. Joshi Marg, Mumbai - 400 011.  
Tel : 91-22-2907 1794 / 5441 - Fax : 91-22-2907 1828 - E-mail : bprmh@bbs-trs.com

FY:MLB:2009-2010 24 OCTOBER 2009

TO WHOSOEVER IT MAY CONCERN

This is to certify that around 25 Pumps of SAMTURBO make have been running in our plant for various applications including Stock and Back Water, etc. The performance of these Pumps have been found to be satisfactory.

After-sales service rendered by Fluid-O-Tech Enterprise/Sam Turbo is also excellent.

For BALKRISHNA PAPER MILLS LIMITED,

  
M.L. BHARTHA  
VICE PRESIDENT (TECHNICAL)



## ::: CLIENT CERTIFICATE :::

1<sup>st</sup> Jan, 2010

To whom so ever it may concern

"This is to Certify that we have been using SAM TURBO make MC Pumps TPS+H 100/430 and TPS+H 80/250 for handling 11% and 9.5% consistency pulp for many years. The performance of these pumps has been found to be excellent. Apart from MC Pumps we have hundreds of their pumps performing in our mill over the years at various locations like stock, water, chemicals, liquor etc.to our satisfaction

The after sales service provided by SAM TURBO / ACE MARKETING is also excellent."

  
Devinder Mehta  
Manager Mechanical  
Ballarpur Industries Ltd.  
Yamunanagar



**Ballarpur Industries Limited**

AA ISO 9001 : 2000 Company

Plant Division, Unit : Three Capital, Yamuna Nagar, Haryana - 151 001 (India) Tel : (+) 91-21732-251000, 251001, 251014 Fax : (+) 91-21732-251002  
Registered Office : Ballarpur, Dist: Chandigarh, Maharashtra (India)



**Ballarpur Industries Limited**

**Unit: Ballarpur**

PO : Ballarpur Paper Mills, Dist: Chandigarh, Maharashtra, Pin - 442801  
Phone : +91 - (21732) - 240200, 240211, 240220, 240282, 240445, 240518  
Fax : +91 - (21732) - 240548 e-mail - [india@birla.com](mailto:india@birla.com)



02.06.2005

TO WHOMSOEVER IT MAY CONCERN

We are using "SAM TURBO" M.C. Pumps and centrifugal pumps ( TPS ) for stock and pulp at various locations for consistency upto 12%.

These pumps are in service for more than 9 years and their performance is found to our satisfaction.

We are also using TCH & CPC pumps at various locations for water, chemicals, Black Liquor and white liquor applications.

Overall performance and life of "SAM TURBO" pumps used by is found to be excellent.

After sales support from M/s Sam Turbo Industry Limited and their local dealer M/s Three Star Engineering Corporation, Nagpur is satisfactory.

  
S.K.JAIN  
DY. CHIEF ENGINEER,  
BALLARPUR UNIT





# SAM TURBO INDUSTRY PRIVATE LIMITED

## ::: CLIENT CERTIFICATE :::





## ::: CLIENT CERTIFICATE :::

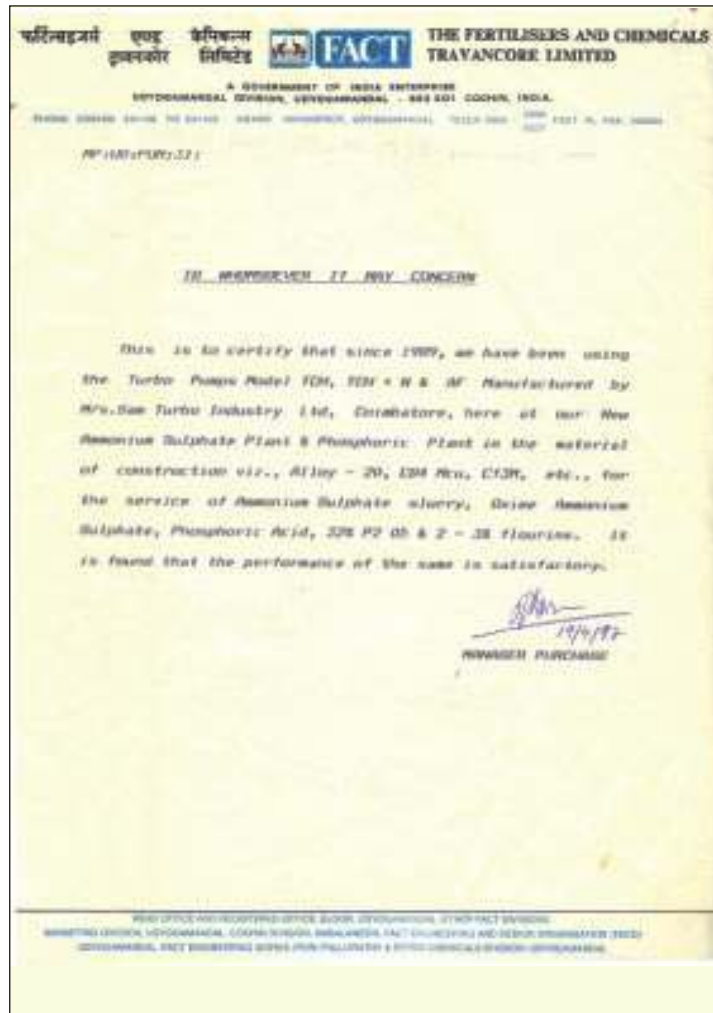

**FACT**  
UDYOGAMANDAL DIVISION

10<sup>th</sup> Oct. 2009

### TO WHOMSOEVER IT MAY CONCERN

We have purchased the following axial flow pumps from M/s. SAM TURBO INDUSTRY LIMITED, and servicing in our Ammonium Sulphate Plants. The details of pumps are as follows:

Model	HSPM 750	HSPM 600
Eng. No.	V-9005 PI	V-9003-PI
Year of purchase	<b>1995</b>	<b>1998</b>
<b>Technical Specifications</b>		
Pumping media	Ammonium Sulphate Slurry	Ammonium Sulphate slurry
Size	750 x 750	600 x 600
Model	AF 750 /670	AF 600 / 530
Capacity	5000 m <sup>3</sup> /hr	3000 m <sup>3</sup> /hr
Head	4 mts.	4 mts.
Speed	593 RPM	735 RPM
Motor Power	110 kw	75 kw
Material of construction	316 L (CF 3M)	316 L (CF 3M)



The performances of these pumps are found to be excellent.

O.A. HARIHARAN,  
Dy. Chief Engineer (Mechanical)



# SAM TURBO INDUSTRY PRIVATE LIMITED

## ::: CLIENT CERTIFICATE :::

 **Genus Paper Products Ltd.**  
(Formerly Kaleesh Paper Products Ltd.)  
(A Hindalco Group Company) 

Regd. Office & Works: Kashi Road, Agrawal Mohan Road - 246 001 India  
Ph: +91 051 25 1171 085730254333 Fax: +91 051 2511842 E-mail: info@genuspapers.com

Date: 16.11.2009

*To whom so ever it may concern*

We certify that more than 100 pumps of SAM TURBO make have been running over the years in our mill for Slurries, Water, Chemical and Liquor applications. The performance of these pumps is found to be excellent. We have saved tremendous on power after using their energy efficiently pumps.

After sales service provided by SAM TURBO ACE MARKETING is too good to compare.

For Genus Paper Products Ltd.  
Jitesh Singh  
VP Tech

Corporate Office : 1-108, DDA Flatted Area Phase I, New Delhi - 110 059, India  
REGD. OFFICE : SUN TURBO INDUSTRY PRIVATE LIMITED, Plot No. 378831, E-Phase, Gurgaon, Haryana

Date: 22.03.2010

  
**TO WHOMEVER IT MAY CONCERN**

Over the last 15/20 years we have a large number of SAM make pumps operating in our plant.

The models in service include AR, ARL, TCH, CPC, TPS, SVN & VO (vertical). SAM pumps are being used for services like different types of slurries, spent liquor, caustic liquor, water & acid.

The overall performance and life of these pumps are excellent. Timely deliveries were received for our various project expansions.

These pumps were procured through M/s Ace Marketing P Ltd., New Delhi who are their authorized dealer for North India. Ace Marketing & Sam have always rendered very good pre & after sales service to us.

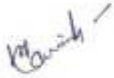
For Hindalco Industries Ltd.  
  
Vivek Srivastava  
Manager Maintenance

**HINDALCO INDUSTRIES LTD.**  
H-1, Sector-27, Gurgaon, Haryana  
Corporate Office: Gurgaon Phase, DDA Flatted Road, Gurgaon, Haryana - 122 002, India





# SAM TURBO INDUSTRY PRIVATE LIMITED

Excellence ▶ Through ▶ Innovation

| Home | About us | Infrastructure | Products | Clientele List | Client Certificate | Contact | Feedback | Sign out |

## ::: CLIENT CERTIFICATE :::

Ph. : 2511232, 2511040  
Fax : 2511742

**KE** To,  
**M/s ACE Marketing Pvt. Ltd.**  
B-55&56, Viharakama Colony,  
Pul Pottladpur, M.B. Road,  
New Delhi-64  
Ph. 29363570, 79  
Fax 29367705

**KAILASH PAPERS**  
(A Unit of Kailash Paper Products Ltd.)  
Office : Village Aghasapur, Kasith Road,  
MORADABAD-244501

Kind Attn: Mr. Anurodh Sharma

Dear Sir,

With ref to your quotation and subsequent discussion with our Mr. Neeraj Sharma and the undersigned on 01.10.2004 & on 02.10.2004, we are pleased to place our **LOI** as per following

- \*Total Nos. of pumps for new project - **53 Nos.**
- \*Boiler feed pumps - **3 Nos.**
- \*Replacement for existing SAM make pumps - **3 Nos.**
- \*Replacement for existing KSB pumps - **6 Nos.**
- \*Total Package agreed for supply of above **Rs. 31.5 Lacs.**

Above price is FOR Moradabad, C&T inclusive, E.D. etc are applicable at the time of supply.

Detailed order along with 10% advance follow.

Thanking you

For Kailash Papers  
Unit: Kailash Paper Product Ltd.

Kailash Agrawal  
Director



**KHANNA** 27/12/2005

To whomsoever it may concern

This is to certify that following 'SAM TURBO' make pumps are working satisfactorily in our Drinking Plant.

TAG NO.	PUMP DESCRIPTION	CAPACITY (M3/Hr)	HEAD (Mtr.)	PUMP MODEL
1	03PPC07 POHRE STOCK PUMP	1800	30	TPS 200/300 (8 VCI)
2	03PPC14 POHRE STOCK PUMP	1800	30	TPS 250/300 (5VCI)
3	03PPC03 HDC FEED PUMP	600	4E	TPS 250/500 (5VCI)
4	03PPC13 STOCK FEED PUMP (LOOP 1)	700	4E	TPS 200/500 (5VCI)
5	03PPC01 FEED PUMP TO PRIME MAGCEL	1475	30	TPS 300/400 (8VCI)
6	03PPC03 FEED PUMP TO PRIME MAGCEL STAGE 1	1475	20	MF 380/500
7	03PPC04 STOCK RECIRCULATION PUMP TO MAGCEL (MAC AERATION STAGE 1 FEED PUMP)	1475	20	MF 300/300
8	04PPC03 STOCK FEED PUMP TO 1ST STAGE CLEANERS	3400	40	ZM II 375/500
9	03PPC10 STOCK FEED PUMP TO FINE SCREEN FEED	900	43	TPS 300/400 (4 VCI)
10	04PPC01 FEED PUMP TO MAC CELL (1ST STAGE)	1475	2E	TPS 300/400 (8VCI)
11	03PPC03 STOCK FEED WATER PUMP TO DISC FILTER	1820	20	MF 380/500
12	03PPC01 STOCK TRANSFER PUMP	1000	30	TPS 300/400 (8 VCI)

APART FROM ABOVE MANY OF SAM TURBO MAKE PUMPS INCLUDING STOCK, LIQUOR, CHEMICALS AND WATER HAVE BEEN RUNNING SATISFACTORILY IN OUR PLANT FOR THE LAST MANY YEARS.

"AFTER SALES SERVICE PROVIDED BY M/S. ACE MARKETING / SAM TURBO IS ALSO EXCELLENT".

For Khanna Paper Mills Pvt Ltd

J V LAD  
AGM (Purchase)

**Khanna Paper Mills Private Limited**

Address : Fatehgarh Road, Amritsar-143001 Punjab, India Ph. : +91-183-5067100 to 106 Fax : +91-183-5067110/111 E-mail : : info@khannapaper.com Regd. Office : H-6A, Lajpat Nagar, Part II New Delhi-110024 Ph. : +91-11-26631922/262



# SAM TURBO INDUSTRY PRIVATE LIMITED

Excellence ▶ Through ▶ Innovation

| Home | About us | Infrastructure | Products | Clientele List | Client Certificate | Contact | Feedback | Sign out |

## ::: CLIENT CERTIFICATE :::

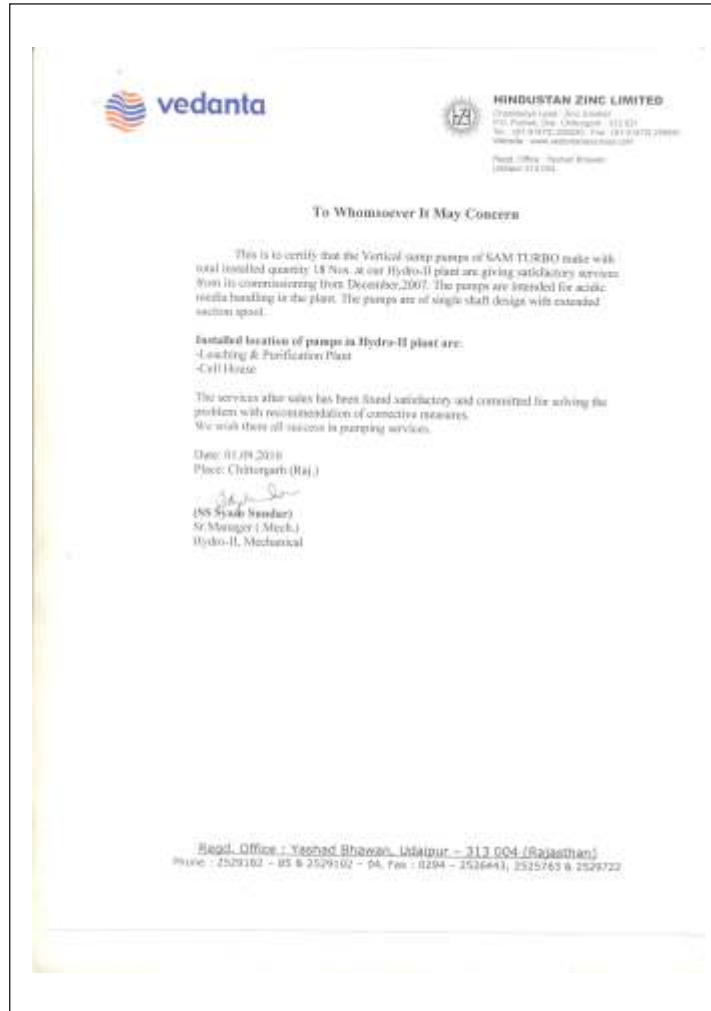



## ::: CLIENT CERTIFICATE :::



**From:** K.S.Vataliya [mailto:ksvataliya@nimma.co.in]  
**Sent:** None  
**To:** bharat parikh  
**Cc:** mechanical\_kalatalav@nimma.co.in; NimmaMViraniAHD  
**Subject:** Fw: SAM TURBO Pumps  
**Importance:** High

Dear Sir,

The performance of the Vertical Sump Pumps in NI-Resist DGB material supplied as per the attached list have been generally found satisfactory.

This is for your kind information please.

With Kind Regards,

K S Vataliya  
Asst. General Manager - Mechanical,

Plant Address :-  
Nirma Limited  
Chemical Complex,  
Village - Kalatalav,  
Dist. - Bhavnagar - 364 313, Gujarat, India  
Phone : +91 - 278 - 2885301 - 2 - 3 - 4, Ext. 122,  
Fax : +91 - 278 - 2885309, 2885319  
e-mail : [ksvataliya@nimma.co.in](mailto:ksvataliya@nimma.co.in)

PS:BCP/2009/3390  
25/01/2010



## ::: CLIENT CERTIFICATE :::

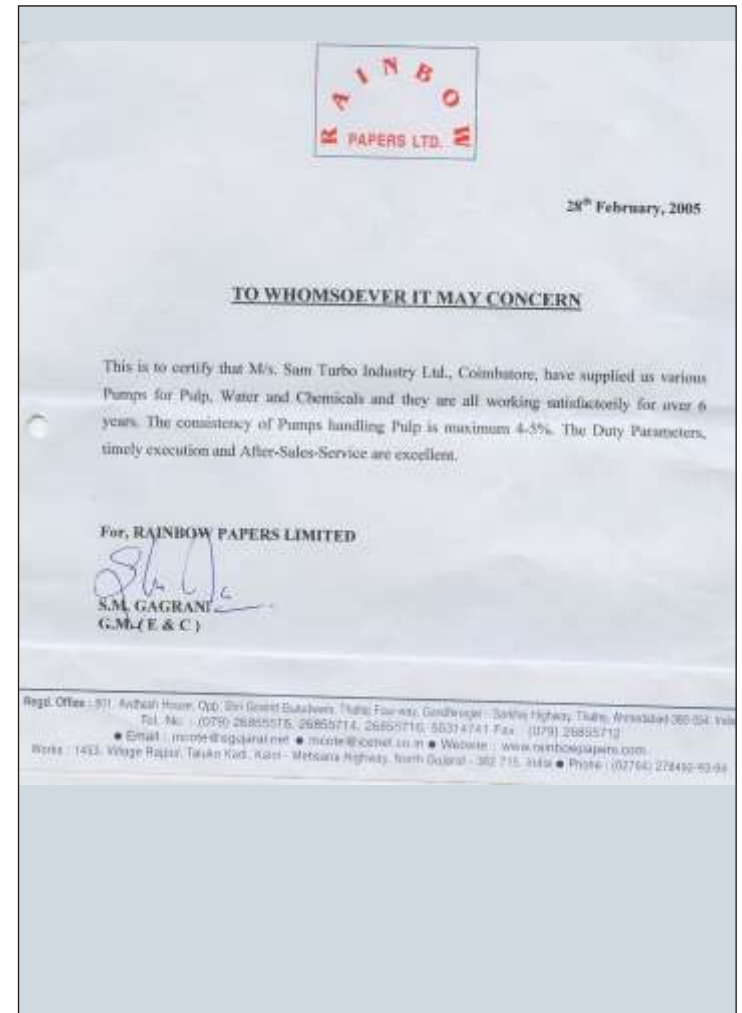



## ::: CLIENT CERTIFICATE :::







## ☰ CONTACT ☰



Excellence ▶ *Through* ▶ Innovation

## SAM TURBO INDUSTRY PRIVATE LIMITED

Avinashi Road, Neelambur,  
Coimbatore - 641 062  
Tamilnadu, INDIA

Phone : +91-422-3058899  
Fax : +91-422-3058000

E-mail : [info@sampumps.com](mailto:info@sampumps.com)

E-mail : [mktg@sampumps.com](mailto:mktg@sampumps.com)

[www.sampumps.com](http://www.sampumps.com)



## Tell us more about you

Name

Company

Position

Address

Email

Phone

Describe the Product you are Interested :